

# Gopher Sign Co. - Bill of Materials

| ITEM NO. | Part Number | DESCRIPTION                                | QTY. | LENGTH | ANGLE1 | ANGLE2 | Bounding Box Area (ft2) | Sheet Metal Thickness |
|----------|-------------|--|------|--------|--------|--------|-------------------------|-----------------------|
| 1.1      | 803509      | ILoc Welded Extrusion<br>2 x 1.625 x 0.125 | 4    | 24     | 45°    | 45°    | 0.00                    |                       |
| 1.2      | 802930      | 0.125" Formed Wall<br>Bracket              | 2    |        |        |        | 1.32                    | 0.125                 |

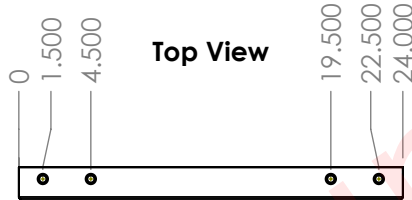

Left View

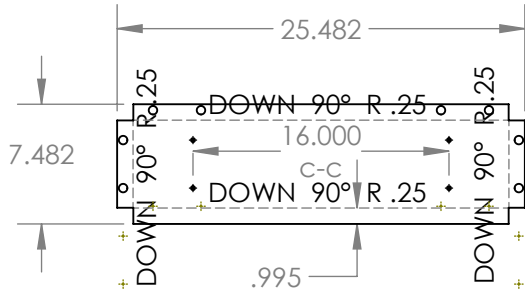
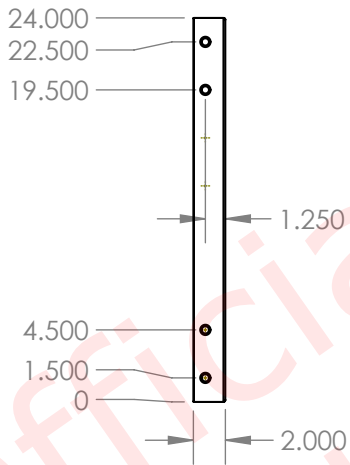

Front View

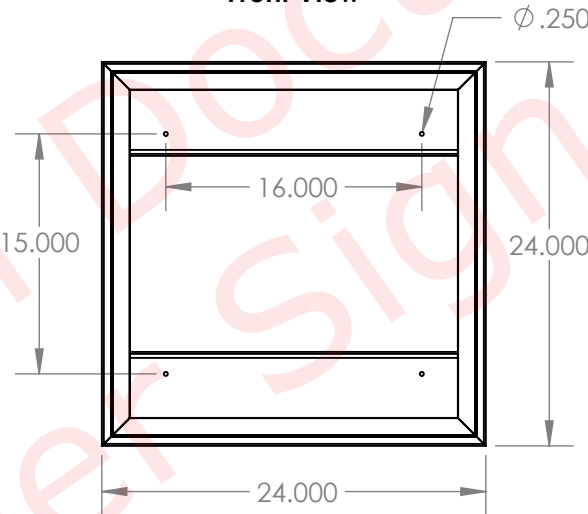

Isometric View

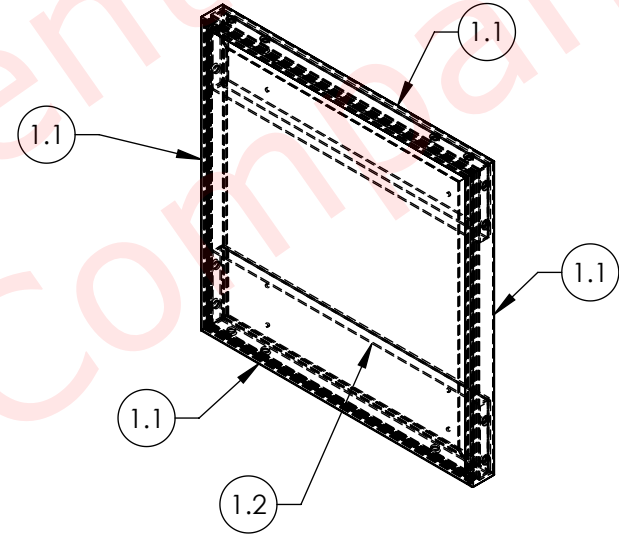

**Hardware:**

- 203911 -Qty. 16 pcs 5/16" x 3/4" black oxide flat head bolts
- 204818 -Qty. 16 pcs 5/16" short nut inserts

Wednesday, September 21, 2022 10:28:13 AM

**PROPRIETARY AND CONFIDENTIAL**  
 THE INFORMATION CONTAINED IN THIS DRAWING IS THE SOLE PROPERTY OF Gopher Sign Company. ANY REPRODUCTION IN PART OR AS A WHOLE WITHOUT THE WRITTEN PERMISSION OF Gopher Sign Company IS PROHIBITED.

DO NOT SCALE DRAWING

Job# \_\_\_\_\_  
 FINISH: \_\_\_\_\_

UNLESS OTHERWISE SPECIFIED:  
 DIMENSIONS ARE IN INCHES  
 TOLERANCES:  
 FRACTIONAL: ± 1/16"  
 ANGULAR: BEND ± 1°  
 TWO PLACE DECIMAL: ± 0.06"  
 THREE PLACE DECIMAL: ± 0.030"

DRAWN: Jonas R. 9/21/2022  
 COMMENTS: \_\_\_\_\_

**-Gopher Sign Company-**  
 103 Highway 22 E - Clear Lake, SD 57226

TITLE:  
**Framed Wall Mount**

SIZE DWG. NO. REV  
**A 190220**

SCALE: 1:24 WEIGHT: SHEET 1 OF 3

1

2

3

4

C

C

B

B

A

A

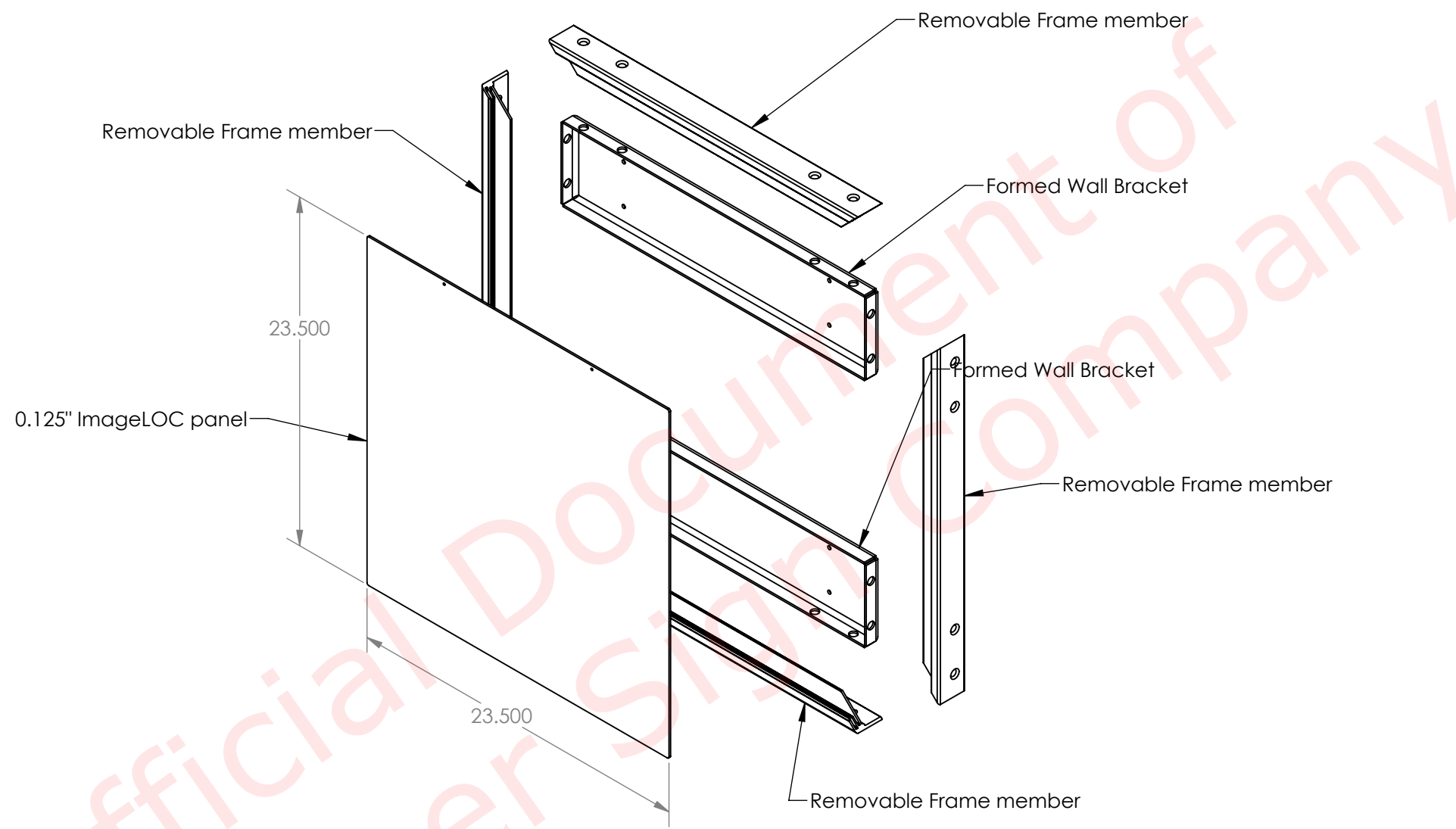

Removable Frame member

Removable Frame member

23.500

Formed Wall Bracket

0.125" ImageLOC panel

Formed Wall Bracket

23.500

Removable Frame member

Removable Frame member

Qty.

UNLESS OTHERWISE SPECIFIED:

DIMENSIONS ARE IN INCHES  
 TOLERANCES:  
 FRACTIONAL ± 1/16"  
 ANGULAR: BEND ± 1°  
 TWO PLACE DECIMAL ± 0.06"  
 THREE PLACE DECIMAL ± 0.030"

**-Gopher Sign Company-**  
 103 Highway 22 E - Clear Lake, SD 57226

TITLE:  
 Exploded View

DO NOT SCALE DRAWING

**PROPRIETARY AND CONFIDENTIAL**  
 THE INFORMATION CONTAINED IN THIS DRAWING IS THE SOLE PROPERTY OF Gopher Sign Company. ANY REPRODUCTION IN PART OR AS A WHOLE WITHOUT THE WRITTEN PERMISSION OF Gopher Sign Company IS PROHIBITED.

Job# \_\_\_\_\_  
 FINISH: \_\_\_\_\_

|                |           |
|----------------|-----------|
| NAME           | DATE      |
| DRAWN Jonas R. | 9/21/2022 |
| COMMENTS:      |           |

|          |               |     |
|----------|---------------|-----|
| SIZE     | DWG. NO.      | REV |
| <b>A</b> | <b>190220</b> |     |

Wednesday, September 21, 2022 10:28:13 AM

SCALE: 1:8 WEIGHT: SHEET 2 OF 3

1

2

3

4

1

2

3

4

Frame Front View

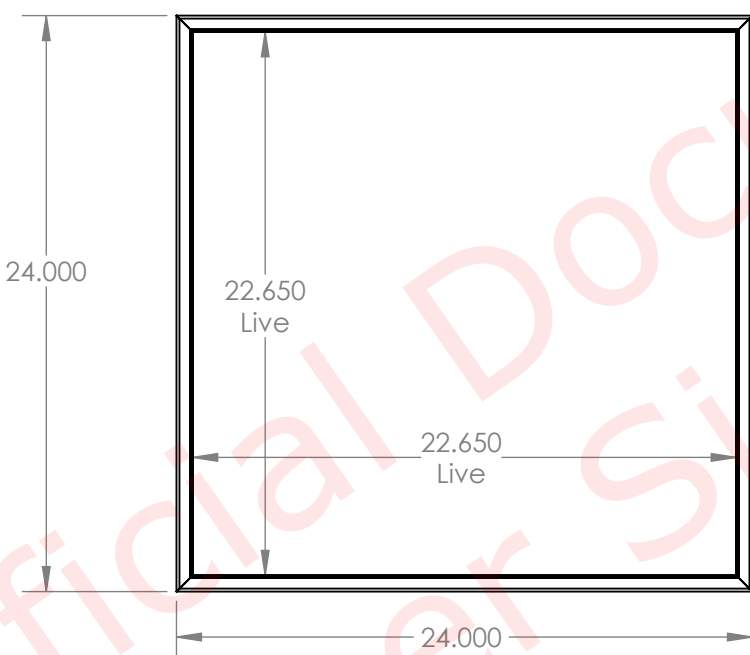

Frame Isometric View

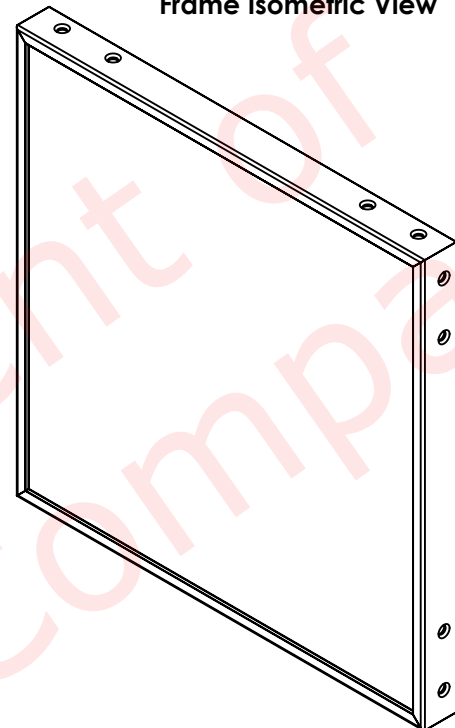

Qty.

UNLESS OTHERWISE SPECIFIED:  
 DIMENSIONS ARE IN INCHES  
 TOLERANCES:  
 FRACTIONAL  $\pm 1/16"$   
 ANGULAR: BEND  $\pm 1^\circ$   
 TWO PLACE DECIMAL  $\pm 0.06"$   
 THREE PLACE DECIMAL  $\pm 0.030"$

**-Gopher Sign Company-**  
 103 Highway 22 E - Clear Lake, SD 57226

TITLE:  
 Frame Detail

DO NOT SCALE DRAWING

**PROPRIETARY AND CONFIDENTIAL**  
 THE INFORMATION CONTAINED IN THIS DRAWING IS THE SOLE PROPERTY OF Gopher Sign Company. ANY REPRODUCTION IN PART OR AS A WHOLE WITHOUT THE WRITTEN PERMISSION OF Gopher Sign Company IS PROHIBITED.

Job# \_\_\_\_\_  
 FINISH: \_\_\_\_\_

|                |           |
|----------------|-----------|
| NAME           | DATE      |
| DRAWN Jonas R. | 9/21/2022 |
| COMMENTS:      |           |

|          |               |     |
|----------|---------------|-----|
| SIZE     | DWG. NO.      | REV |
| <b>A</b> | <b>190220</b> |     |

SCALE: 1:8    WEIGHT:    SHEET 3 OF 3

Wednesday, September 21, 2022 10:28:13 AM

1

2

3

4